



The Leading Manufacturer of Vertical Form Fill
and Seal Packaging Solutions

GIC8100



The GIC8100 is a high-speed constant motion servo machine best suited for gusseted, quad or doy pack formats or where the product requires a high-care environment. The GIC8100 can pack bag widths up to 400mm and incorporates robust, proven mechanical design and the latest Allen Bradley maintenance-free servo technology to ensure industry-leading reliability and low cost of ownership.

Applications

The GIC8100 is suitable for a wide range of applications including (but not limited to): Fresh and frozen foods, snacks and confectionery, powders and pulses, salad, herbs, and protein.

Integration

The GIC3000 is designed to integrate with all types of infeed feed systems; including, multi-head weighers (MHW), augers, linear weighers, volumetric pumps, counters and cup fillers. Downstream plant interface connections are also provided.

Pack Styles



Pillow

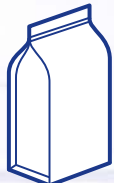

Quad



Gusseted

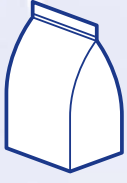

Block Bottom



Doy



Zip

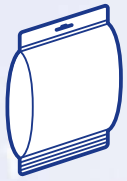

Euroslot

GIC8100

MAXIMUM FINISHED FLAT BAG WIDTH: 400mm

MAXIMUM SPEED: 160 PACKS PER MINUTE

POWER SUPPLY: 3 PHASE SUPPLY – 415V 3PH + N AND E. 25A PER PHASE D RATED

COMPRESSED AIR REQUIREMENT: DEPENDENT ON SPEED AND APPLICATION

FINISH: BLACK HARD ANODISED ALUMINIUM AND STAINLESS STEEL

PACKAGING MATERIALS: ALL SUITABLE HEAT SEALABLE MATERIALS INCLUDING LAMINATES AND POLYETHYLENES (OPTIONAL IMPULSE SEALING). CAN BE ADAPTED FOR PAPER

REEL OUTER DIAMETER: 480mm

REEL CORE DIAMETER: 76mm

WEIGHT: 1100kg

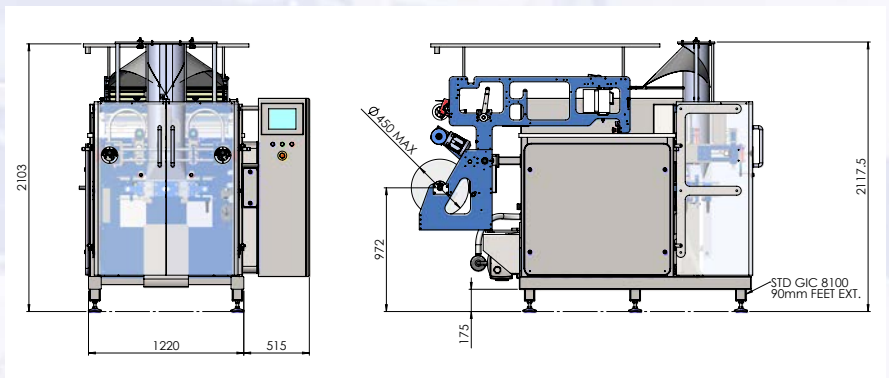

GIC8100 Machine Specification

- Full maintenance-free Allen Bradley Kinetix 5500 Servo Drives x 5
- Allen Bradley Compact Logix PLC
- Full feature 10-inch colour Allen Bradley panel view plus 7 1000 MMI touch screen
- Rotary band back seal system
- Servo driven twin belt film transport with vacuum assist
- Drop on air mandrel, allows for easy loading of film
- Hinged electrical enclosure for dual sided access
- Full SMC pneumatics with additional manifold capacity built-in
- Pneumatic mechanical web tension control with electronic monitored actuation
- 'High Care Environment' specification as standard
- Reel run out sensor
- Manual film tracking incorporating coder and labeller
- Wrapper print registration (PEC)
- Provision for integrated coder mounting and print roller
- Manual splice table with integrated tape dispenser
- Pack discharge chute
- PETG safety guards (10mm thick) complete with safety switches

Optional Features

- Continuous film feed mounted quad sealing system
- Full servo driven automatic pack gusseting/block bottom
- Remote access
- Gas flushing
- Impulse poly-welding and alternative sealing systems
- Label application and print options
- Discharge elevator
- Pack turning device
- Carry bag handle application

GIC Ltd
Alpha Works, Heapham Road Industrial Estate
Gainsborough, Lincolnshire DN21 1RZ

+44 127 611885 info@gic.uk.net

www.gic.uk.net f in t

