



The Leading Manufacturer of Vertical Form Fill
and Seal Packaging Solutions

GIC CUB



The CUB is a compact pneumatic machine ideal for producing pillow packs with bag widths of up to 150mm. The machine can be upgraded to a Stainless-Steel finish for high-care environments. Operating from a single-phase power supply (240V as standard), the CUB has a simple-to-operate Allen Bradley touchscreen, incorporating a robust mechanical design allowing clear access for clean down and maintenance.

Applications

The CUB is suitable for a wide range of applications including (but not limited to): snacks and confectionery, hardware, and powders.

Integration

The CUB is designed to integrate with all types of infeed feed systems, including; multi-head weighers (MHW), augers, linear weighers, volumetric pumps, counters and cup fillers. Downstream plant interface connections are also provided.

Pack Style



Pillow

CUB Machine Specification:

- Full feature Allen Bradley MMI touch screen complete with Allen Bradley MicroLogix 1000 PLC
- Pneumatically operated jaw mechanism
- Inverter driven single belt film transport
- Full SMC pneumatics
- Manual film tracking
- Serrated cut off knife
- Progressive mechanical web tension control
- Reel run out sensor
- Low level cantilevered film feed mandrel
- PETG safety guards (10mm thick) complete with safety switches
- Wrapper print registration (PEC)
- Provision for integrated Coder mounting and anvil plates

Optional Features

- Full stainless steel and high care upgrade
- Discharge elevator
- Print options
- Remote access
- Impulse (poly) welding and alternative sealing systems

GIC CUB

MAXIMUM FINISHED FLAT BAG WIDTH: 150mm

MAXIMUM SPEED: 50 PACKS PER MINUTE

POWER SUPPLY: 240V SINGLE PHASE 13A

COMPRESSED AIR REQUIREMENT: DEPENDENT ON SPEED AND APPLICATION

FINISH: BLACK HARD ANODISED ALUMINIUM AND STAINLESS STEEL, MILD STEEL ENCLOSURE (UPGRADABLE ON REQUEST)

PACKAGING MATERIALS: ALL SUITABLE HEAT SEALABLE MATERIALS INCLUDING LAMINATES AND POLYETHYLENES (OPTIONAL IMPULSE SEALING)

MAXIMUM REEL OUTER: 330mm

REEL CORE DIAMETER: 76mm

WEIGHT: 550kg

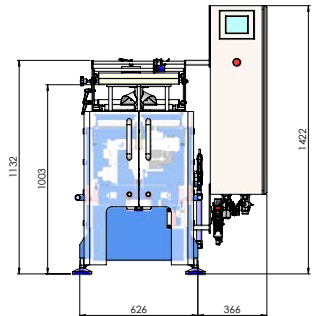
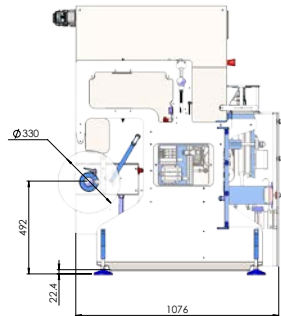
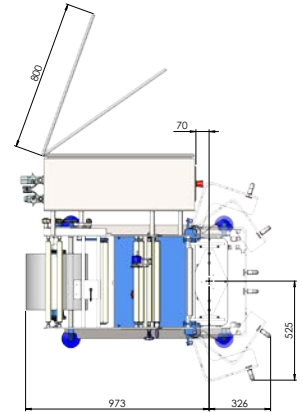
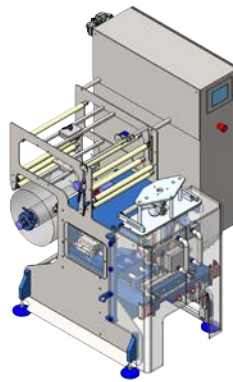

GIC Ltd
Alpha Works, Heapham Road Industrial Estate
Gainsborough, Lincolnshire DN21 1RZ

+44 127 611885 info@gic.uk.net

www.gic.uk.net f in t

