



The Leading UK Manufacturer of Vertical Form Fill and Seal Packaging Solutions.

**UK** Manufacturing  
Since 1984

# GICCUB

## Vertical Form Fill Seal Bagging Machine

### Machine Information

#### Overview

Very compact design. Low cost of ownership, proven robust mechanical and electrical design. High quality materials used for the most demanding environment. Single phase power supply (240V as standard). Simple to operate Allen Bradley HMI touch-screen. Maximum access for clean-down and maintenance.

#### Applications

The **GICCUB** can package a wide variety of products including Bullion (Coin), Confectionery, Hardware, Cereals, Confectionery and Powders.

#### Integration

The **GICCUB** integrates seamlessly with various upstream equipment such as check-weighers, multi-head weighers, augers, pumps, cup fillers and counters. The **GICCUB** also integrates with all downstream equipment.

#### Leading Technology

The **GICCUB** incorporates robust mechanical design with new counter balance system for higher speed application. The machine is fitted with latest Allen Bradley platform. The result is industry leading reliability and low cost of ownership.

### Pack Formats



Pillow

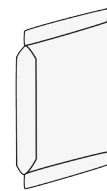

Gusseted

# GICCUB

## Vertical Form Fill Seal Bagging Machine

### Standard Features...

- PLC Control System
- Motorised single belt wrapper feed
- Allen Bradley HMI touch-screen
- Film feed tracking adjustment
- Reel run out sensor
- Pneumatically operated horizontal seal jaws
- Product in seal' detection

### Optional Features...

- Print registration unit
- Discharge pack elevator
- Machine castors
- Overprinters
- Feed systems (dependent on application)

### Specification

Maximum Pack Sizes: 150mm W x 250mm L  
Maximum Speed: 60 packs per min  
Power Supply: 240V single phase 13A  
Compressed Air: Free air - 0.27 cubic mtrs/min  
d.eependent on speed and application  
Finish: Black hard anodised aluminium and painted mild steel  
Packaging Materials: All suitable heat sealable materials including laminates  
Maximum Reel Outer: 330mm  
Reel Core diameter: 76mm  
Weight : 550kg

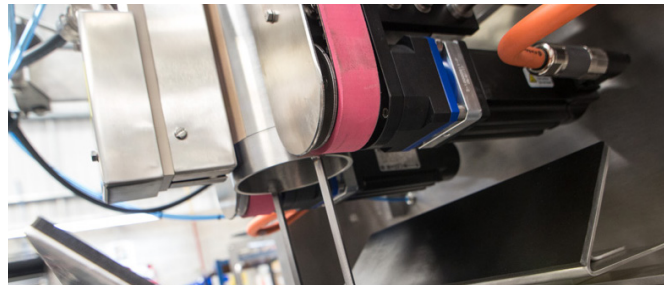

### Technical Diagrams - GICCUB

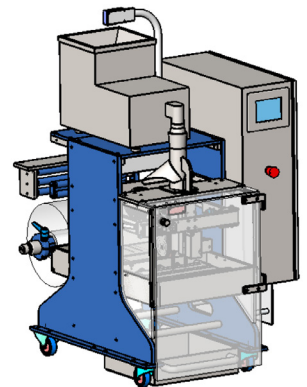
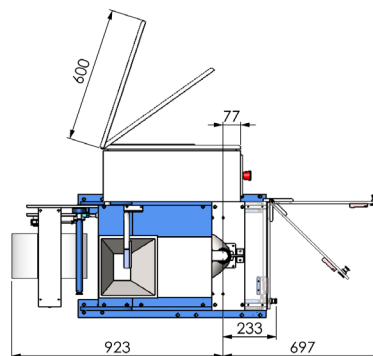
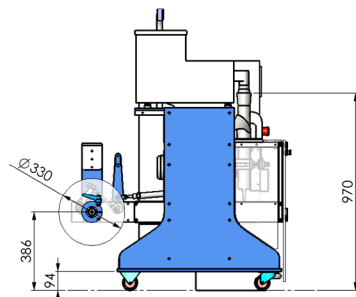
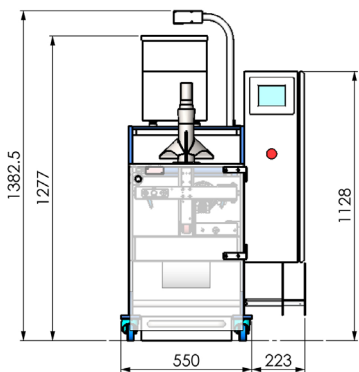

GIC Ltd, Alpha Works, Sandars Road, Heapham Road Industrial Estate, Gainsborough, Lincolnshire, DN21 1RZ

Tel: +44 (0)1427 611885 | Email: [info@gic.uk.net](mailto:info@gic.uk.net) | Web: [www.gic.uk.net](http://www.gic.uk.net)

For all enquiries in the North of England, Scotland and Ireland call Martin Raison on : 07710 714267  
For all enquires in the South of England & Wales call Keith Marrow on : 07872 129272