



The Leading UK
Manufacturer of
Vertical Form Fill
and Seal Packaging
Solutions.

UK Manufacturing
Since 1984



GIC3100

Vertical Form Fill Seal Bagging Machine

Machine Information

Overview

The **GIC3100** is ideal for high speed bag styles upto 250mm wide, such as pillow gusseted and block bottom. The machine can also be manufactured to accomodate quad, doy and zip applications.

Applications

The **GIC3100** can package a wide variety of products including fresh produce, snacks, confectionery, pet food, powders, pulses, pasta, liquids and non-foods.

Integration

The **GIC3100** integrates seamlessly with various upstream equipment such as check-weighers, multi-head weighers, augers, pumps, cup fillers and counters. The **GIC3100** also integrates with all downstream equipment.

Leading Technology

The **GIC3100** incorporates robust mechanical design with new counter balance system for higher speed application. The machiner is fitted with latest Allen Bradley platform. The result is industry leading reliability and low cost of ownership.

Pack Fortmats



Pillow

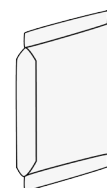

Gusseted

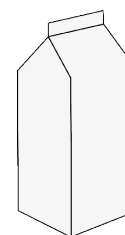

Block Bottom

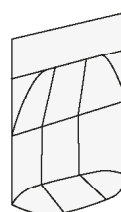

Doy

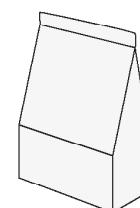

Quad

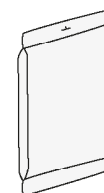

Euroslot

GIC3100

Vertical Form Fill Seal Bagging Machine

Standard Features...

- 10 inch Operator friendly HMI colour touch screen with multi access facility
- Full latest specification Allen Bradley Servo Drives
- Enclosed main frame and sealed panel
- Stainless steel and hard anodised aluminium finish
- Low Level Drop on air shaft
- Film Splice
- Toolless size change facility
- Reel run out detection
- Fully integrated coder station
- Fully integrated labeller station
- Product in seal detection
- Heat Seal Crimp Jaws with out of tolerance temperature sensor
- Film Transport with individual drives
- Upto 200 product codes available
- GIC counter balanced system

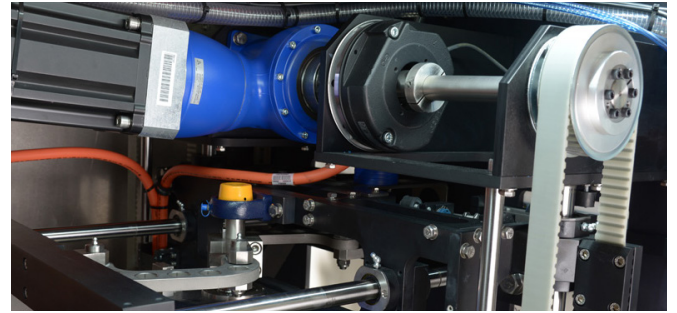

Full Allen Bradley Five Axis Servo drive System as Standard

Optional Features...

- Full stainless steel and high care kit.
- Gas flushing
- Block Bottom \ Gussetting \ Quad \ Doy \ Zip\ Euroslot available
- Impulse polywelding
- Label application
- Remote Access for diagnostics and software upgrades
- Discharge pack elevator
- Pack turning device
- Carrier bag handle option

Specification

Weight: 1100kg

Maximum Pack Sizes: 250mm Wide x 400mm Long

Maximum Speed: 160 packs per min

Power Supply: 415V 3-phase 3kW (4kW for servo option)

Compressed Air: Free air – 0.06 cubic mtrs/min dependent on speed and application.

Finish: Stainless steel and anodised aluminium

Packaging Materials: All suitable heat sealable materials including laminates and polyethylenes (optional impulse sealing).

Reel Outer Diameter: 450mm (max reel weight 75kg)

Reel Core Diameter: 76mm

Technical Diagrams - GIC3100 (model shown with right hand HMI)

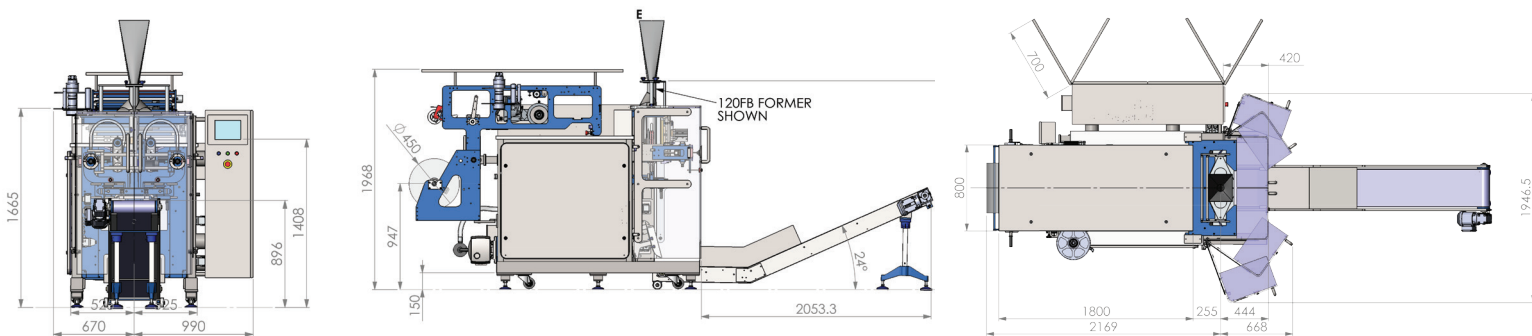

GIC Ltd, Alpha Works, Sandars Road, Heapham Road Industrial Estate, Gainsborough, Lincolnshire, DN21 1RZ

Tel: +44 (0)1427 611835 | Email: info@gic.uk.net | Web: www.gic.uk.net

For all enquiries in the North of England, Scotland and Ireland call Martin Raison on : 07710 714267
For all enquiries in the South of England & Wales call Keith Marrow on : 07872 129272