

GIC3000



The GIC3000 is a high-speed continuous motion servo machine ideal for producing a wide range of pack formats with bag widths of up to 250mm. The GIC3000 incorporates robust proven mechanical design and the latest Allen Bradley maintenance-free servo technology to ensure industry leading reliability and low cost of ownership.

Applications

The GIC3000 is suitable for a wide range of applications including (but not limited to);- Fresh and frozen foods, snacks and confectionery, powders and pulses, salad, herbs and protein.

Integration

The GIC3000 is designed to integrate with all types of infeed feed systems; including, multi-head weighers (MHW), augers, linear weighers, volumetric pumps, counters and cup fillers. Downstream plant interface connections are also provided.

Pack Styles



Pillow

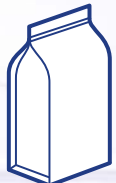

Block Bottom



Punch Hole



Euroslot



Zip

GIC3000

MAXIMUM FINISHED FLAT BAG WIDTH: 250mm

MAXIMUM SPEED: 115 PACKS PER MINUTE

POWER SUPPLY: 3 PHASE SUPPLY – 415V 3PH + N AND E. 25A PER PHASE D RATED

COMPRESSED AIR REQUIREMENT: DEPENDENT ON SPEED AND APPLICATION

FINISH: BLACK HARD ANODISED ALUMINIUM AND STAINLESS STEEL

PACKAGING MATERIALS: ALL SUITABLE HEAT SEALABLE MATERIALS INCLUDING LAMINATES AND POLYETHYLENES (OPTIONAL IMPULSE SEALING). CAN BE ADAPTED FOR PAPER

REEL OUTER DIAMETER: 450mm

REEL CORE DIAMETER: 76mm

WEIGHT: 1100kg

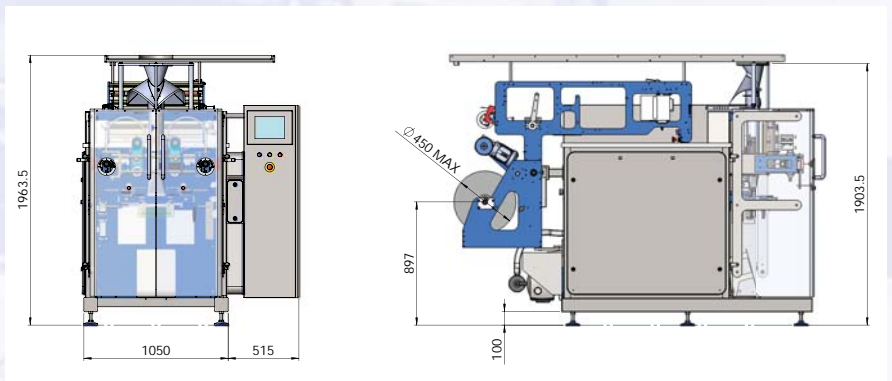

GIC3000 Machine Specification

- Full maintenance-free Allen Bradley Kinetix 5500 Servo Drives
- Allen Bradley Compact Logix PLC
- Full feature 10-inch colour Allen Bradley panel view plus 7 1000 MMI touch screen
- Servo driven twin belt film transport with vacuum assist
- Rotary band back seal system fitted as standard
- Wrapper print registration (PEC)
- Reel run out sensor
- Low level cantilevered film feed air mandrel, allows for easy loading of film reels
- Full SMC pneumatics with additional manifold capacity built-in
- Pneumatic mechanical web tension control with electronic monitored actuation
- Manual film tracking incorporating coder and labeller
- Pack discharge chute
- Provision for integrated Coder mounting and print roller
- Manual splice table with integrated tape dispenser
- PETG safety guards (10mm thick) complete with safety switches

Optional Features

- Remote access
- Full stainless steel and high care upgrade
- Gas flushing
- Impulse poly-welding and alternative sealing systems
- Label application and print options
- Discharge elevator
- Pack turning device
- Bag shaker
- Deflator unit
- Carry bag handle application
- Static eliminator

GIC Ltd
Alpha Works, Heapham Road Industrial Estate
Gainsborough, Lincolnshire DN21 1RZ

+44 127 611885 info@gic.uk.net

www.gic.uk.net f in t

