



The Leading Manufacturer of Vertical Form Fill
and Seal Packaging Solutions

GIC5100



The GIC5100 is an intermittent motion servo machine ideal for producing a wide range of pack formats with bag widths up to 500mm. The GIC5100 incorporates a robust, proven mechanical design and the latest Allen Bradley maintenance-free servo technology to ensure industry-leading reliability and low cost of ownership.

Applications

The GIC5100 is suitable for a wide range of applications including (but not limited to): Aggregates, pet foods, powders, pulses, and hardware. The GIC5100 can be supplied within a self-contained trailer system specifically designed to work in quarries.

Integration

The GIC5100 is designed to integrate with all types of infeed feed systems; including, multi-head weighers (MHW), augers, linear weighers, volumetric pumps, counters and cup fillers. Downstream plant interface connections are also provided.

Pack Styles



Pillow

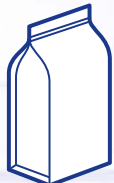

Quad



Gusseted

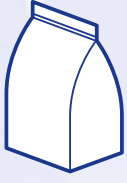

Block Bottom



Zip



Punch Hole



Euroslot

GIC5100

MAXIMUM FINISHED FLAT BAG WIDTH: 500mm

MAXIMUM SPEED: 30 PACKS PER MINUTE

POWER SUPPLY: 3 PHASE SUPPLY – 415V 3PH + N AND E. 25A PER PHASE D RATED

COMPRESSED AIR REQUIREMENT: DEPENDENT ON SPEED AND APPLICATION

FINISH: BLACK HARD ANODISED ALUMINIUM AND STAINLESS STEEL

PACKAGING MATERIALS: ALL SUITABLE HEAT SEALABLE MATERIALS INCLUDING LAMINATES AND POLYETHYLENES (OPTIONAL IMPULSE SEALING). CAN BE ADAPTED FOR PAPER

REEL OUTER DIAMETER: 600mm

REEL CORE DIAMETER: 76mm

WEIGHT: 2200kg

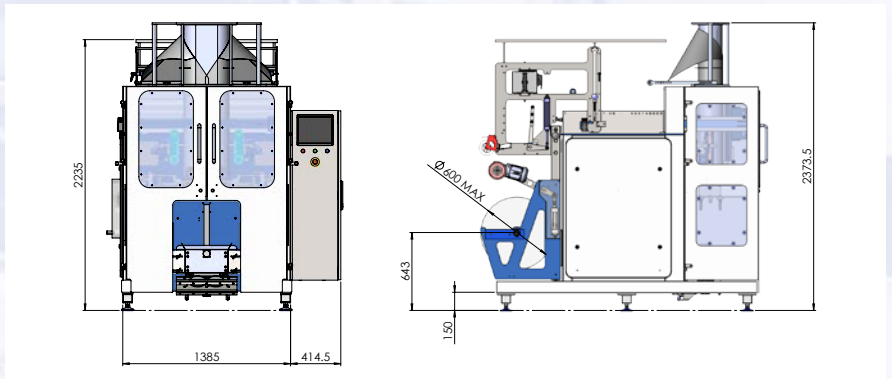

GIC5100 Machine Specification

- Full maintenance-free Rockwell Allen Bradley Kinetix 5500 servo drives
- Allen Bradley Compact Logix PLC
- Full feature 10-inch colour Allen Bradley panel view plus 7 1000 MMI touch screen
- Single reel drop on air mandrel with SEW motor/gearbox powered unwind assisted drive
- Powder coated steel frames, guard panels and electrical enclosure
- Serrated cut off knife
- Full SMC pneumatics with additional manifold capacity built-in
- Pneumatic mechanical web tension control with electronic monitored actuation
- Reel run out sensor with auto machine stop and alarm
- Wrapper print registration (PEC) with manual adjustment for 'long-reach' films
- Manual film tracking incorporating coder and labeller
- Heavy duty discharge bag support table with motorised height adjustment
- Provision for integrated coder mounting and anvil plates
- Manual splice table with integrated tape dispenser
- Full size, fully interlocked twin front mild steel guard doors complete with safety switches

Optional Features

- Remote access
- Stainless steel and black hard anodised aluminium upgrade
- Gas flushing
- Impulse poly-welding and alternative sealing systems
- Label application and print options
- Discharge elevator
- Pack turning device
- Static eliminator
- Bag shaker
- Deflator unit
- Selectable multi-pull transport cycles
- Adjustable pack support

GIC Ltd
Alpha Works, Heapham Road Industrial Estate
Gainsborough, Lincolnshire DN21 1RZ

+44 127 611885 info@gic.uk.net

www.gic.uk.net f in t

